



SYMBIOTIC TECHNOLOGY

STEAMBOX "H" offers two methods of generating steam: boiler-generated and instant mode. Working in synergy, these two methods make it possible to gain the maximum advantage from the two individual systems and overcome their limitations. These advantages are easy to measure in terms of speed, efficiency, energy-saving and steam quality.

RecipeTuner

The RecipeTuner interface makes it possible to modify and personalise the various programs simply and intuitively. RecipeTuner changes according to the type of cooking set, to regulate cooking, browning, degree of humidity and of leavening.

EasyService

level control cooking

The new Rack Control enables different dishes to be cooked at the same time at various levels. What's more, with EasyService, a new Rack Control function, all the dishes can be served at the same time.

steamtuner

Steambox is fitted with a patented system that makes it possible to adjust the moisture level in the steam, setting this to the right degree of dryness or wetness that the cooking method requires.



To guarantee a perfectly balanced climate inside the cooking chamber, Giorik has patented a unique humidity control system (Meteo System) using software that analyses the relevant parameters in the cooking chamber and then regulates the production of steam or discharges excess humidity.

TECHNICAL FEATURES

- Heating of cooking chamber with PREMIX GAS BURNER.
- Rapid chamber ventilation system.
- Meteo system (patented) for humidity control in the cooking chamber.
- Inverter-controlled fan with 6 different speeds.
- Immediate shutdown of the fan rotation by opening the door
- Steam production with Symbiotic technology (patented).
- Steam tuner (patented) for tuning dry-wet steam.
- USB port for uploading and saving recipes and for firmware updating.
- Double-glazed ventilated door (panels can be opened for easy cleaning).
- Cooking chamber lighting with LED.
- AISI 304 cooking chamber with coved corners.
- Height adjustable feet.
- Single control by means of just one jog/dial encoder knob.
- Motorised vent valve opening.

STANDARD EQUIPMENT

- Core probe 6000120
- Retractable hand shower
- Automatic washing system (tabs or liquid) - automatic descaling of boiler.

OPTIONS:

- Optional rack for 60x40 trays.
- Left hinged door (as optional).

USER INTERFACE:

TOUCH SCREEN PANEL 9"

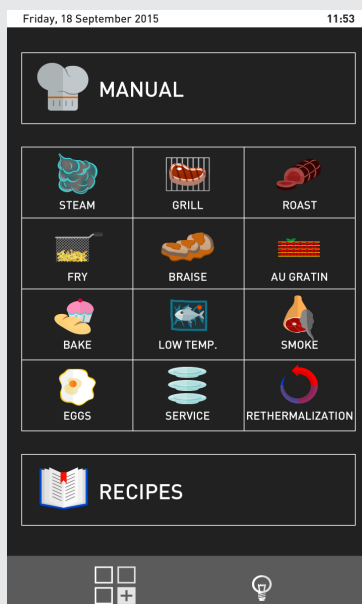

- Temperature control from 30° to 300°C.
- Time control from 1'to120'; infinite function.
- Cooking modes: convection, steam, combi convection/steam.
- Preset cooking programmes. Possibility of controlling 9 cooking phases for each programme.
- Delta T cooking.
- Cooking with probe.
- Multi level cooking with "Easy service".
- Cooking chamber humidity control (Meteo system).
- Steam tuner: dry-wet steam.
- Cooldown during cooking.
- Hold function.
- Regeneration function.

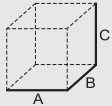
 (A x B x C) cm	VOL./PESO Vol./Weight m ³ /kg	VAC 230-1N 50Hz (60 Hz optional) kW	POTENZA GAS CAMERA Oven cavity gas power kW	DISTANZA TRA LE TEGLIE Distance between the layers mm	DIM. CAMERA Cavity net dimension mm
86x79,5x83,5 6 GN 1/1	0,62 / 142	1,4	12	70	445x660x470

ACCESSORIES

- Stand TSB06
- Racks for stand TSB06 cod. 2019768
- Neutral cupboards TAN0800
- Heated cupboard TAC0800
- Stacking kit on demand

ACCESSORIES FOR PATISSERIE USE

- 2025121 racks 60x40 size 80.

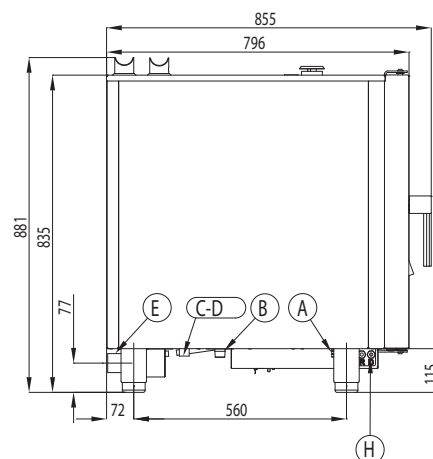
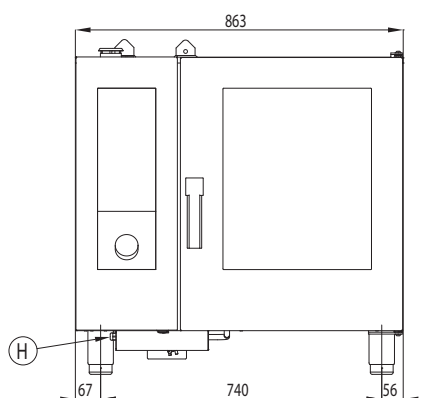

- A Electrical power inlet
- B Gas inlet (R3/4)
- C Softened water inlet (G3/4)
- D Water inlet valve (G3/4)
- E Drain connection (Ø50)
- F Cavity Vent (Ø50)
- G Gas fumes exhaust (Ø50)
- H Detergent and rinse aid inlet

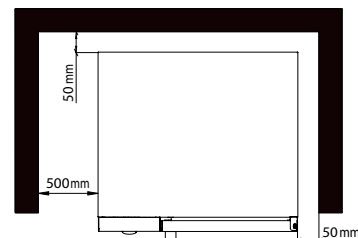
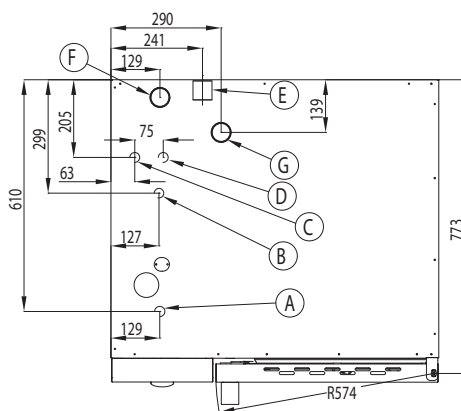

* Clearance requirements

WATER QUALITY REQUIREMENTS

Hardness	60-100 ppm
TDS	<100 mg/L
PH Value	7.0-8.0
Cl ₂ Free chlorine.....	<0,5 mg/L
Cl Chloride.....	<20 mg/L
Alkalinity.....	<20 mg/L
SiO ₂ Silica.....	<10 mg/L

NOTE

* Drain line must be vented